



---

**STEP 1:** Read the Safety section before starting. See page 3.

**STEP 2:** Install the sign(s). See “Mechanical installation” on page 5.

**STEP 3:** Mount the temperature probe. See page 8.

**STEP 4:** Make all of the necessary electrical connections. See page 9.

**STEP 5:** Check the time displayed on the sign. See page 13.

---

© Copyright 2002–2004 Adaptive Micro Systems LLC. All rights reserved.

Adaptive Micro Systems • 7840 North 86th Street • Milwaukee, WI 53224 USA • 414-357-2020 • 414-357-2029 (fax) • <http://www.adaptivedisplays.com>  
Trademarked names appear throughout this document. Rather than list the names and entities that own the trademarks or insert a trademark symbol with each mention of the trademarked name, the publisher states that it is using names for editorial purposes and to the benefit of the trademark owner with no intention of improperly using the trademark.

The following are trademarks of Adaptive Micro Systems: Adaptive, Alpha, AlphaLert, AlphaNET, AlphaNet plus, AlphaEclipse, AlphaPremiere, AlphaTicker, AlphaVision, AlphaVision InfoTracker, Automode, BetaBrite, BetaBrite Director, BetaBrite Messaging Software, Big Dot, Director, EZ KEY II, EZ95, PagerNET, PPD, PrintPak, Serial Clock, Smart Alec, Solar, TimeNet.  
The distinctive trade dress of this product is a trademark claimed by Adaptive Micro Systems LLC.

Due to continuing product innovation, specifications in this manual are subject to change without notice.

---

## Contents

---

Safety . . . . .	3
Warnings and cautions . . . . .	3
Battery backup . . . . .	4
Preventing electrostatic discharge damage . . . . .	4
Mechanical installation . . . . .	5
Designing the support structure . . . . .	5
Lifting the sign . . . . .	5
Mounting the sign . . . . .	6
Mounting the temperature probe . . . . .	8
Electrical installation . . . . .	9
Guidelines for electrical installation . . . . .	9
Connecting power to the sign . . . . .	10
Connecting the temperature probe to the sign . . . . .	11
Connecting signs in a master/slave configuration . . . . .	12
Checking the time . . . . .	13
Troubleshooting . . . . .	14
Appendix . . . . .	15
Sign description . . . . .	15
Outside view . . . . .	15
Inside view . . . . .	16
Controller board . . . . .	17
Opening and closing the sign . . . . .	19
Unlocking and opening the door . . . . .	19
Closing and locking the door . . . . .	21
Removing the control box from the sign enclosure . . . . .	22
Sign Settings . . . . .	25
Setting the time . . . . .	25
Setting the hold time . . . . .	26
Setting the dimming percentage . . . . .	27
Making display selections . . . . .	30
Making symbol selections . . . . .	31
Selecting the font to be displayed . . . . .	32
Using the DIP switches to change sign settings . . . . .	33
Using the control box to change sign settings . . . . .	36
Diagnostic tests . . . . .	37
To run diagnostic tests on a master sign . . . . .	37
To run diagnostic tests on a slave sign . . . . .	37
Sign specifications . . . . .	39
EMI compliance . . . . .	39
To view sign identification information . . . . .	39
Temperature protection . . . . .	39
Cold protection . . . . .	39
Heat protection . . . . .	39
Technical specifications . . . . .	40

## Safety

### Warnings and cautions

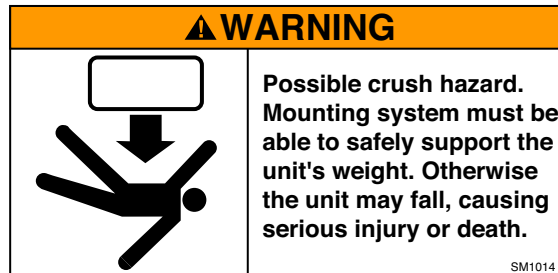

The AlphaEclipse Time and Temperature sign, when improperly handled or mounted, may present a possible crush hazard.

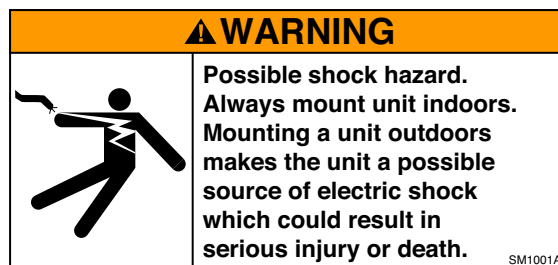

The AlphaEclipse Time and Temperature sign draws a maximum input current of 1 amp. There is a 20-amp circuit breaker built into the sign's internal ON/OFF switch. Each sign should be connected to another external, dedicated 15-20 amp circuit breaker.

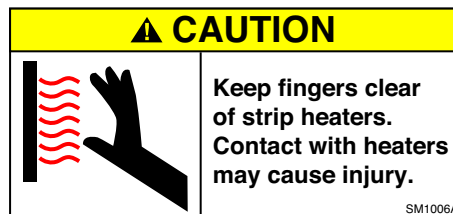

The AlphaEclipse Time and Temperature sign includes a heater strip. Contact with heaters may cause serious injury.

## Battery backup

In the event of a power loss, a backup battery in the AlphaEclipse Time and Temperature sign provides short-term power in order to retain the dimming and hold time settings made using the control box. The backup battery also keeps time.

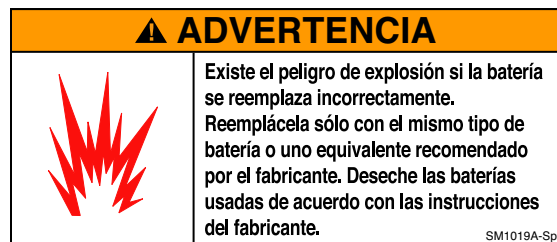
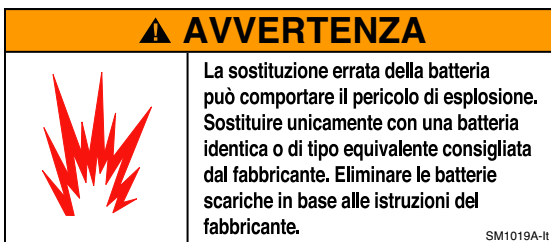
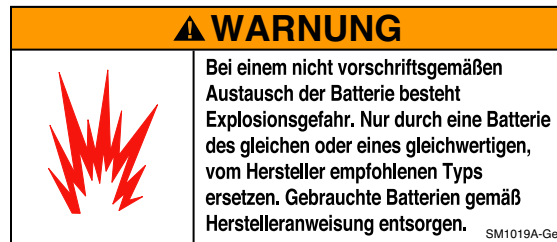
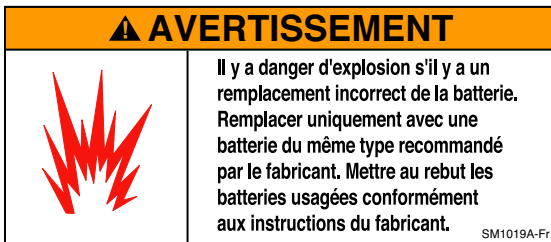
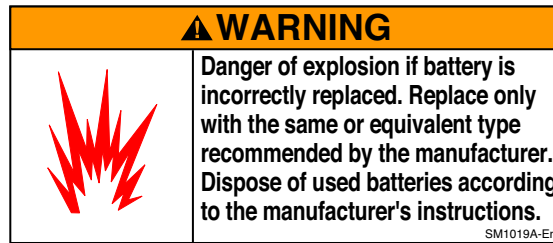

## Preventing electrostatic discharge damage



This equipment contains components that may be damaged by “static electricity”, or electrostatic discharge. To prevent this from happening, be sure to follow the guidelines in Adaptive Tech Memo 00-0005, “Preventing Electrostatic Discharge (ESD) Damage,” available on our Web site at <http://www.adaptivedisplays.com>.

## Mechanical installation

The first step in installing your AlphaEclipse Time and Temperature Sign(s) is to mount each sign. There are three factors to consider when mounting a sign: designing the support structure, lifting the sign, and mounting it in its permanent location.

### Designing the support structure

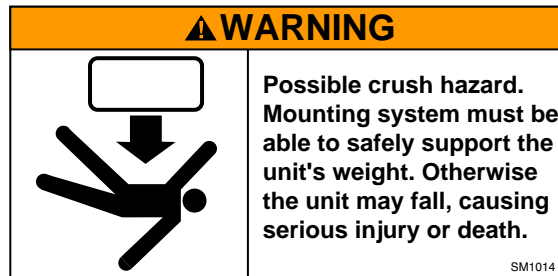

The design of the support structure depends on the mounting methods, sign size, sign weight, and wind loading. Support structure design should only be done by a qualified individual.

It is the customer's responsibility to ensure that the support structure and sign mounting hardware are capable of supporting the sign and are in compliance with all applicable building codes.

Adaptive Micro Systems is not responsible for installations or the structural integrity of support structures done by others.

### Lifting the sign

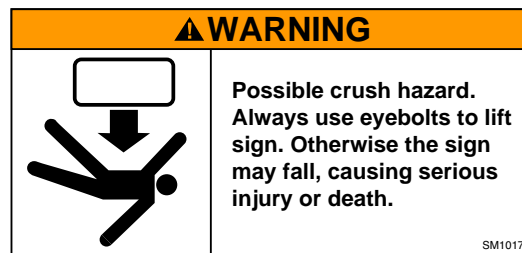
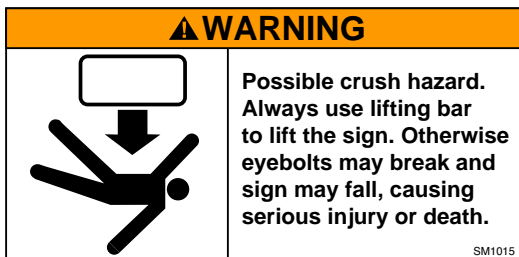

Use the two eyebolts on the sign with a lifting bar to raise the display. Do not use the lifting bolts to permanently hang or mount the sign. Remove the bolts after installation.

Holes are provided in the upper mounting support bar for the lifting bolts.

A spreader bar should be used to maintain a vertical force on each lifting bolt to avoid dangerous lateral force to the bolts.

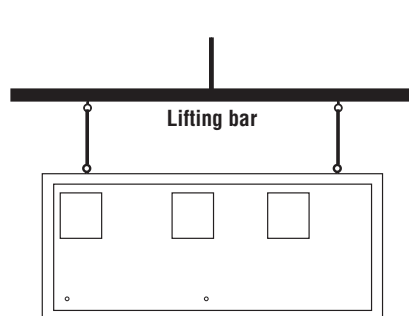

**RIGHT WAY  
TO LIFT SIGN**

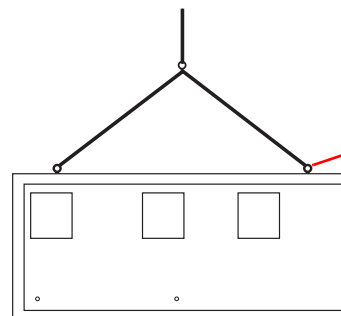

The eyebolts may shear off if the sign is lifted this way.

**WRONG WAY  
TO LIFT SIGN**

## Mounting the sign

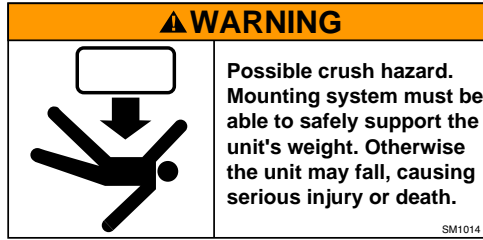

Because every installation site is unique, there is no single, Adaptive-approved procedure for mounting an AlphaEclipse Time and Temperature sign.

However, follow these guidelines when installing a sign:

- Consult with a professional sign installer to determine the proper mounting system and to comply with all applicable building codes.
- Only use the sign's mounting support brackets to mount the sign. Mounting to any other parts of the sign will void the warranty.
- All top and bottom mounting support bars should be used to mount the sign.
- If the sign is mounted to a solid surface like a wall, nothing should block the space between the top, bottom, and sides of the sign and the solid surface. If there is an obstruction (as in a monument-style installation), then run ductwork (not supplied) from the bottom of each fan cover to the side edge of the sign. Do *not* run ductwork to the top of the sign as rain or other material could enter the sign. Do *not* run the ductwork to the bottom of the sign as this could force exhaust air back into the sign.

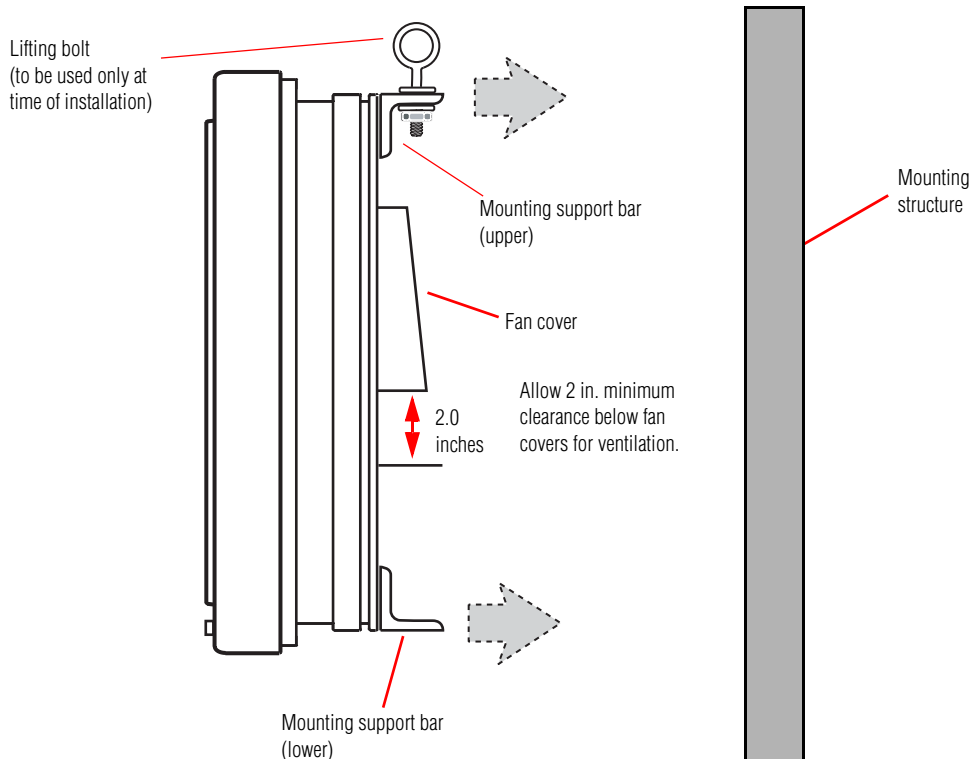

- Drill holes as needed in the sign's mounting support bars for fasteners. Drilling holes in any other place on the sign will void the warranty. Follow these guidelines when drilling holes in the mounting support bars:
  - Drill the minimum number of holes necessary.
  - The distance from the center line of a mounting bolt to the outside edge of a mounting support bracket should *not* be less than two times the diameter of the fasteners.
  - To prevent bi-metal corrosion, dissimilar material should be isolated when mounting the sign.
- Run separate conduits for power and communications connections.
  - A 3/4" opening is provided for the conduit containing power.
  - A 3/4" opening is provided for the conduit containing communications wiring and/or the temperature probe wire.
  - If there are two or more signs in a master/slave configuration, install a junction into the master sign's opening for communications and/or temperature probe wiring. Then run conduit from the junction to the slave sign(s) for the communications wiring.

## Mounting the temperature probe

Care must be taken to observe these considerations when selecting a location for the temperature probe. Not following these guidelines could result in inaccurate temperature probe readings.

- Choose a location where air movement is not restricted by nearby walls or other obstructions. A light-colored background is preferable to a dark-colored mounting background. A location above vegetation is preferable to a location above asphalt or blacktop.
- Mount the temperature probe at least one foot below the eave of a protected overhang so convection currents (rising hot air flow) are not trapped around the temperature probe. Also, make sure convection currents are not blocked by the mounting plates.

A location on the north side of a building or other large structure will afford protection from the afternoon sun. Mount the temperature probe at least 6 feet off the ground. Shield the probe from the effect of the direct sun, reflected heat, or any nearby sources of heat, such as chimneys, vents, or HVAC ducts.

1. Mount the temperature probe vertically using the mounting plate on each side of the probe. The temperature probe can be mounted on either a flat or a curved surface.
2. Connect the cable from the temperature probe to the sign. See “Connecting the temperature probe to the sign” on page 11.

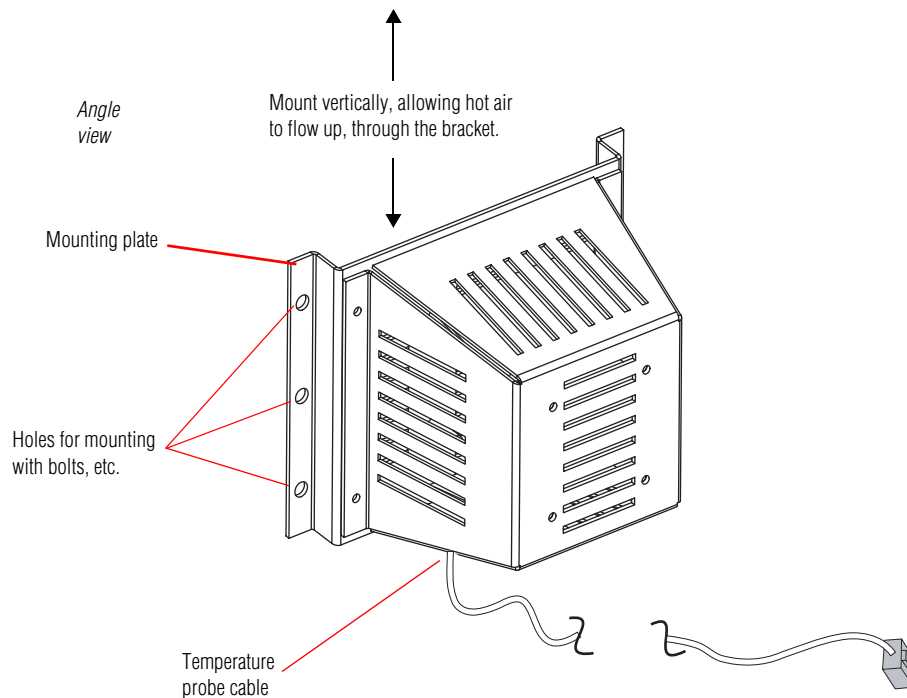



## Electrical installation

After you mount the sign and the temperature probe, the next step in installing your AlphaEclipse Time and Temperature sign is to make all the electrical connections necessary for operation. Connect the power wiring, the temperature probe cable, and, if you are installing more than one sign, the communications wiring.

Electrical installation should only be attempted by a qualified electrician. Electrical connection must comply with all applicable national and local codes.

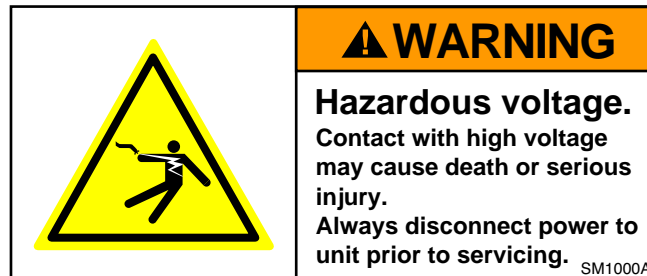

### Guidelines for electrical installation

- Run power wiring from a switched, fused power source.
- Install a two-pole disconnect device in the building wiring for each branch circuit supplying the sign.
- Run separate conduits to the sign for power and communications connections.
- Make all electrical connections watertight.
- Make sure the sign is properly earth grounded. The sign's support structure should *not* be used as ground.
- Use minimum 80° C copper wire only. Torque terminals to 7-10 inch/pounds.

Utiliser uniquement un fil en cuivre pouvant supporter 80° C minimum. Serrer les bornes à 0,79 N/m - 1,13 N/m.

## Connecting power to the sign

**NOTE:** AlphaEclipse Time and Temperature signs are individually designed for either 120-volt or 240-volt power. Be sure to use the appropriate wiring for your sign.

1. Open the sign according to “Unlocking and opening the door” on page 19.
2. Connect 14-8 AWG wires through the Power conduit to the Power terminal block.

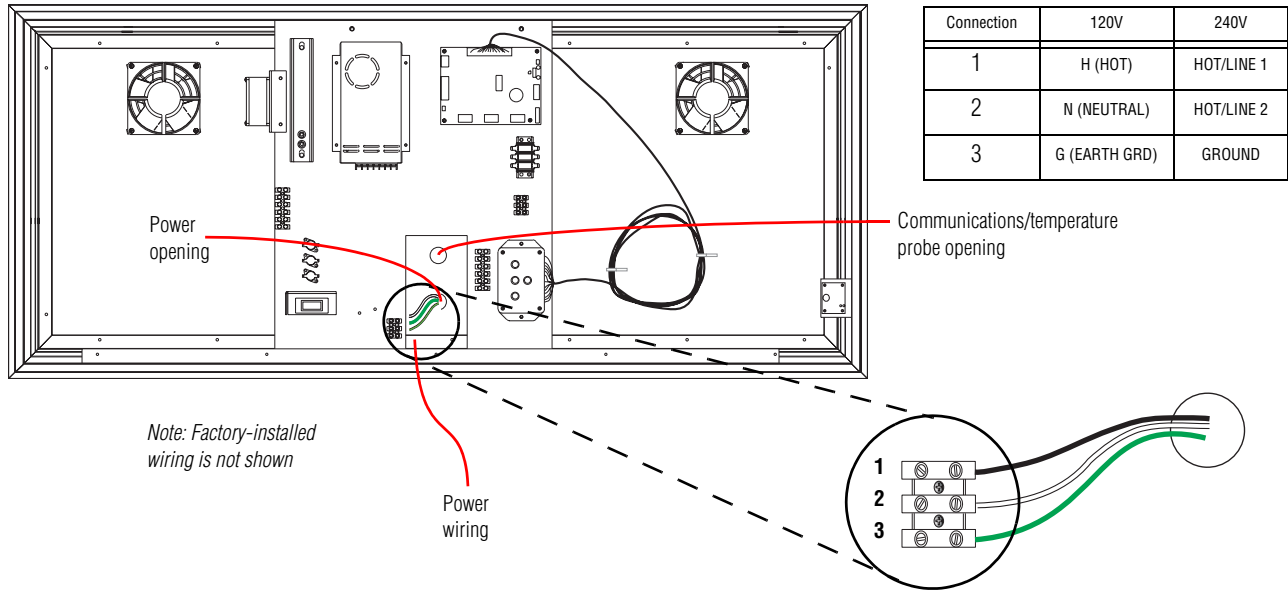

Note: The heater strip and the top and bottom thermostat are not installed in newer signs.

3. Make sure the sign is properly earth grounded.
4. Close the sign according to “Closing and locking the door” on page 21.
5. Apply power to the sign by connecting the power wires to 15-20 amp service.

## Connecting the temperature probe to the sign

1. Open the sign according to “Unlocking and opening the door” on page 19.
2. Run the temperature probe cable through the same conduit opening as the communications wiring.
3. Connect the cable to the controller board as shown.

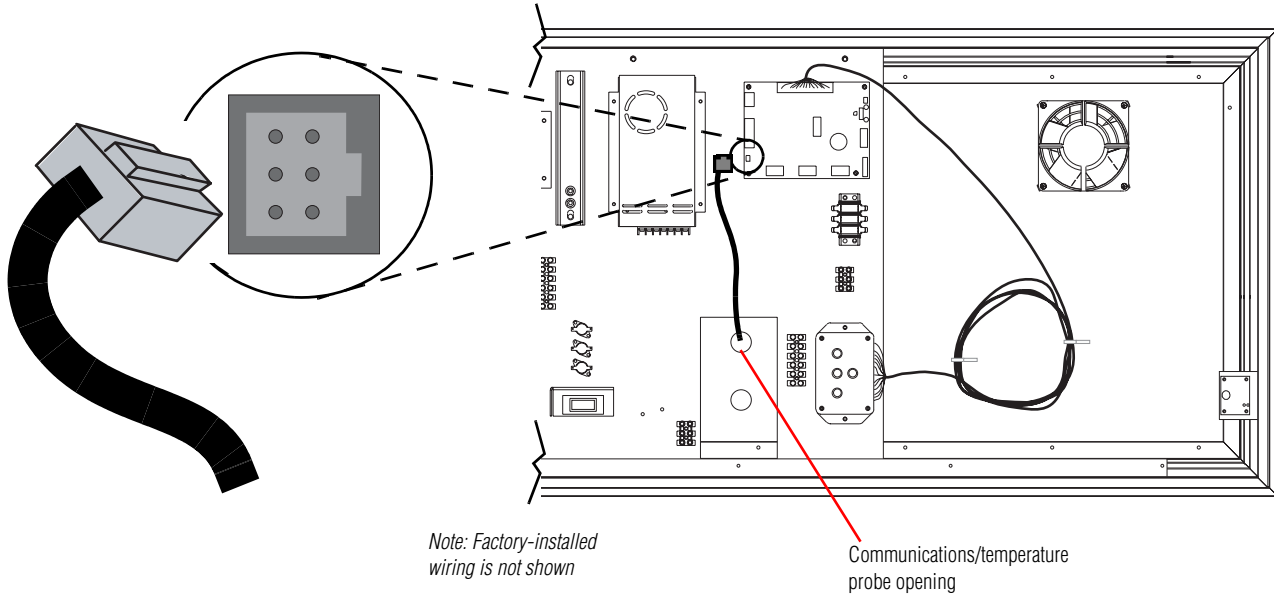

Note: The heater strip and the top and bottom thermostat are not installed in newer signs.

4. Close the sign according to “Closing and locking the door” on page 21.

### Connecting signs in a master/slave configuration

Two signs can be mounted and wired so that both signs always display the same information. The signs are connected in a master/slave configuration using a 25-foot, 2-conductor, shielded RS485 cable (pn 7122-0284). This cable is included in the slave sign. One end is connected to the sign's communications terminal block and the other end is looped and tie-wrapped inside the sign.

1. Open the slave sign according to "Unlocking and opening the door" on page 19.
2. Locate the RS485 cable and cut the tie-wrap.
3. Run the RS485 cable out of the slave sign through the temperature probe/communications conduit opening.



4. Close the slave sign according to "Closing and locking the door" on page 21.
5. Open the master sign.
6. Run the RS485 cable into the conduit opening of the master sign.
7. Connect the wires to the master sign's communications terminal block as shown.

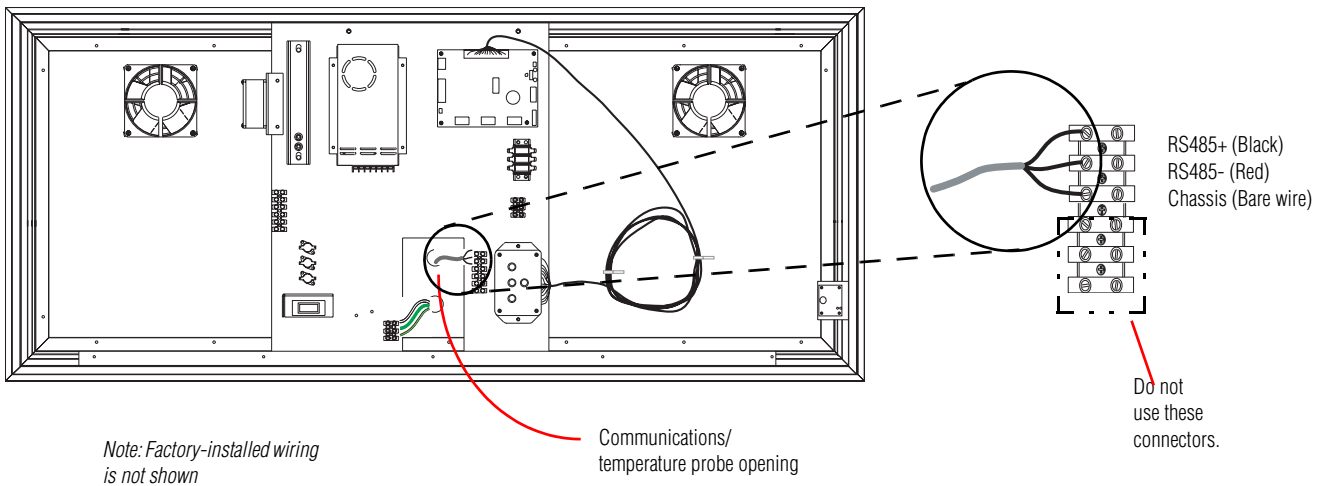

Note: The heater strip and the top and bottom thermostat are not installed in newer signs.

8. Close the master sign.

---

## Checking the time

---

The final step in installing your AlphaEclipse Time and Temperature sign(s) is to make sure that the correct time is displayed on the sign.

When power is applied to the sign, identification information about the sign will be displayed, followed by the time and temperature as they are currently set. To change these settings, see “Sign Settings” on page 25.

## Troubleshooting

Several error conditions can cause unexpected results from the AlphaEclipse Time and Temperature sign. Following are some problems that may occur, the probable cause(s) for each problem, and some suggestions to try to rectify the problem.

Symptom	Cause	What to do
Lines appear under characters 2 through 4 and the colon is lit.	The time is not valid. Power may be absent because of a bad or discharged battery. Or, the sign is new and has not been tested.	Reapply power to the sign for 5 minutes or more. Then reset the time according to See "Setting the hold time" on page 26.
Dashes appear in character positions 1 through 4 and the colon is lit. You are not able to select a time setting with the Select button.	The time is not valid because the internal clock has failed and the correct time cannot be determined.	Call the Adaptive Micro Systems Customer Support department.
	If the sign is a slave in a master/slave configuration, data may not have been received from the master sign.	Check the cables between the signs.
Dashes appear in character positions 1 through 3, and in position 4, the scale units for temperature appears.	The temperature probe cable has become unplugged.	Plug in the cable.
	The temperature probe has failed.	Replace the temperature probe.
Control box settings do not work.	The control box is disconnected.	Reconnect the control box. NOTE: After all settings have been made, the sign can operate correctly without the control box connected.
The sign does not dim as expected.	The Sensor may be disconnected.	Check the connection for the Sensor and plug it in tightly. If that does not work, call the Adaptive Micro Systems Customer Support department.
	Environmental conditions never get dark enough for dimming.	Test by covering the Sensor and the sign should dim.
	If the sign is a slave in a master/slave configuration, the master might be set incorrectly.	Check DIP switches 5 and 6 on Bank 1 on the controller board in the master sign. See "Setting the dimming percentage on a master or single sign with DIP switches" on page 27.
The sign is always dimmed.	Something may be blocking the Sensor.	Remove anything blocking the Sensor.
	The Sensor may be shorted.	Unplug the Sensor. The sign should return to full brightness. Replace the Sensor.
The sign displays an internal temperature of 31° in the diagnostic temperature test.	The internal temperature sensor may have failed.	Call the Adaptive Micro Systems Customer Support department.
The ON/OFF switch turned OFF by itself.	An overcurrent fault may have occurred.	Reset the circuit breaker by turning the ON/OFF switch ON.
Power to the sign has been off for a week or less and the hold time and/or the dimming level – originally set with the control box – need to be set again.	The backup battery may have failed.	Call the Adaptive Micro Systems Customer Support department.

## Appendix

### Sign description

#### Outside view

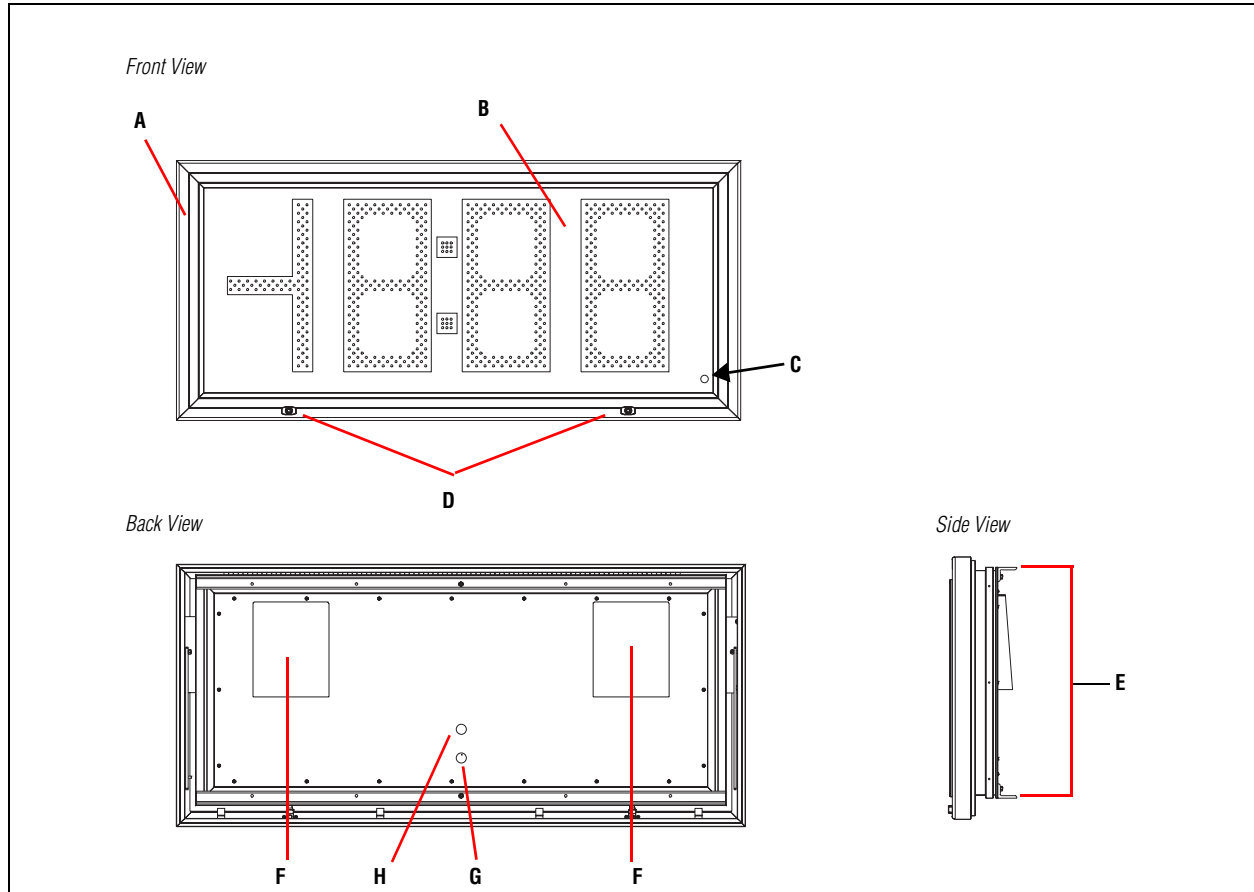

Item		Description
<b>A</b>	Door	Provides access to the inside of the sign.
<b>B</b>	LED lens cover	Polycarbonate lens cover in the front access cover is a replaceable item.
<b>C</b>	Sensor	Used to dim the sign's display in darkness.
<b>D</b>	Locking latch	Locks the sign closed. Requires key (included).
<b>E</b>	Mounting support bars	American Standard 6061-T6 extruded aluminum: 0.25" x 1.5" x 2.0" (ASTM B 308).
<b>F</b>	Fan covers	Weather-resistant louvers allow air movement through the sign.
<b>G</b>	Power conduit opening	3/4" opening for electrical power. Must be sealed with weather-proof conduit during installation.
<b>H</b>	Sign communications/ temperature probe conduit opening	3/4" opening for communications wiring and temperature probe. Must be sealed with weather-proof conduit during installation.

**Inside view**

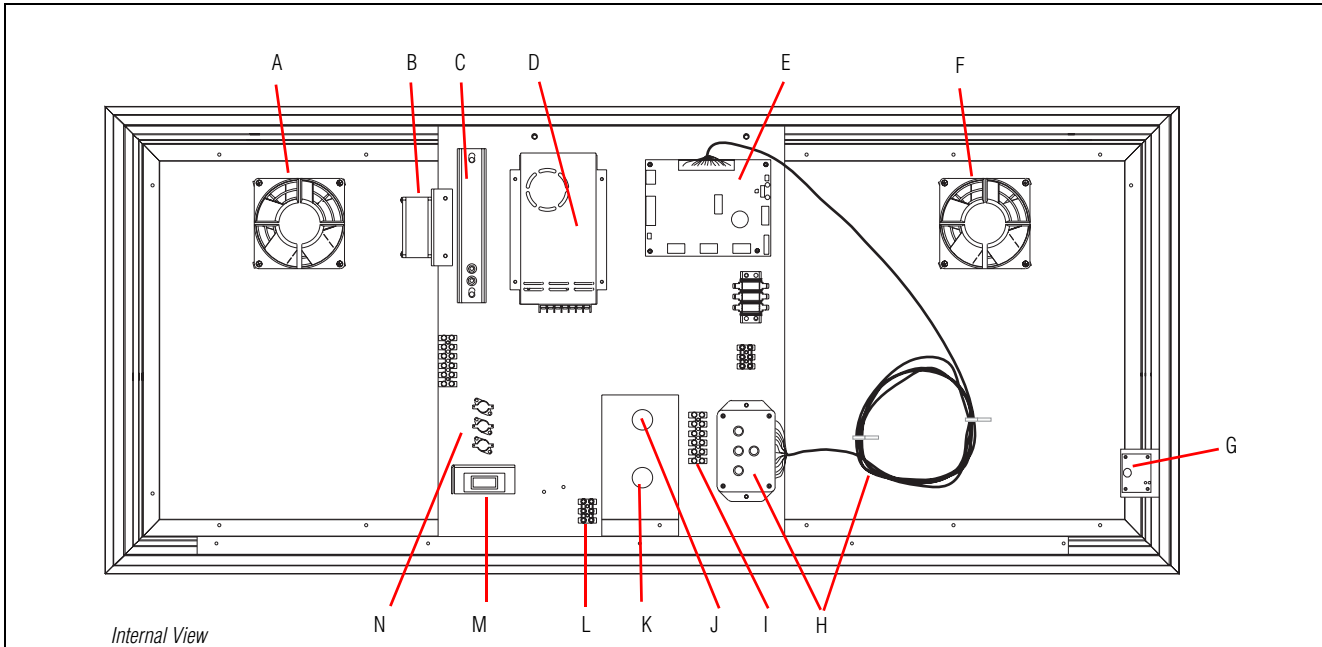

Internal View

Item	Part number	Description
A	46008028	Fan, cooling, exhaust
B	46000009	Fan, for heater strip (Always on when sign has power)
C	30676001 30676002	Heater strip, 120V Heater strip, 240V (not installed in newer signs)
D	40656110	Power Supply
E	11659101	Controller board (See details on next page.)
F	46008028	Fan, cooling, intake
G	11659004	Sensor (single/master models only)
H	11659105	Control box, with 25' connector cable
I	43201029	Communications terminal block
J	N/A	Communications/temperature probe opening
K	N/A	Power line opening
L	43201018	Power terminal block
M	48100002A	ON/OFF switch and circuit breaker
N	30670002 30670755 30670758	Thermostats (not installed in newer signs)



## Controller board

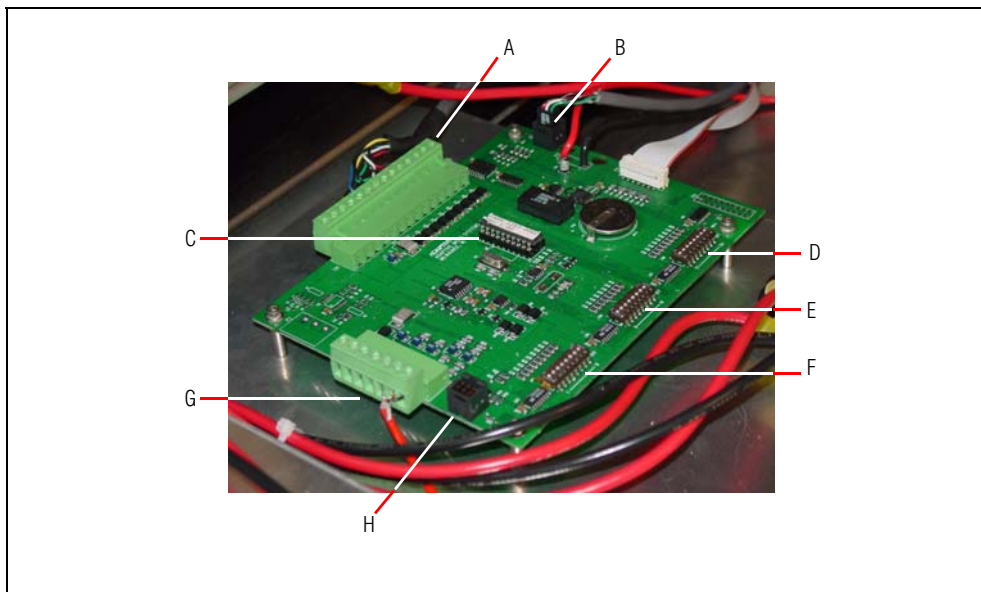

Item	Description
<b>A</b>	Control box connector
<b>B</b>	Sensor connector
<b>C</b>	Micro controller chip with Eprom
<b>D</b>	DIP switch 3
<b>E</b>	DIP switch 2
<b>F</b>	DIP switch 1
<b>G</b>	Communications connector
<b>H</b>	Temperature probe connector

### Control box wiring diagram

Wire	Cable pair	Color
14	N/A	None
13		N/C
12	1	BRN
11		BLK
10	2	YEL
9		BLK
8	3	BLUE
7		BLK
6	4	GRN
5		BLK
4	5	WHT
3		BLK
2	6	RED
1		BLK

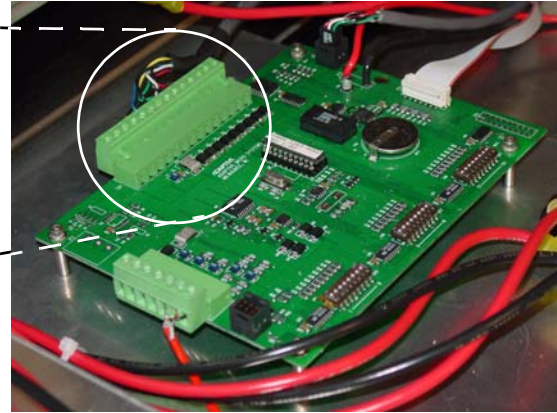
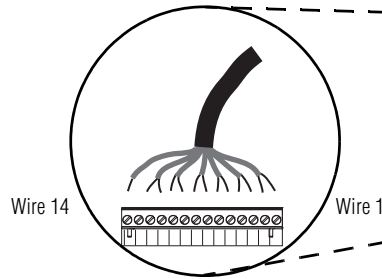

Controller board

Wire numbers are not shown on the connector. They are listed here only to represent the position (sequence) of the wires.

### Communications wiring diagram

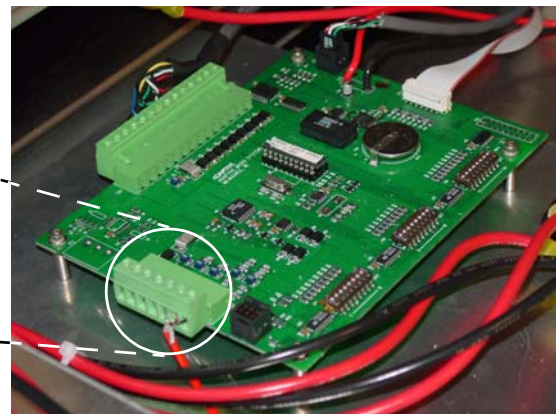
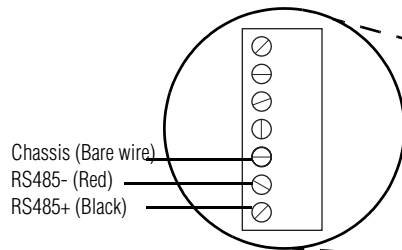

Controller board

## Opening and closing the sign

### Unlocking and opening the door

1. Disconnect power from the sign.
2. Use the latch key to unlock the latches that are located along the lower edge of the sign's front.

Front view of the sign

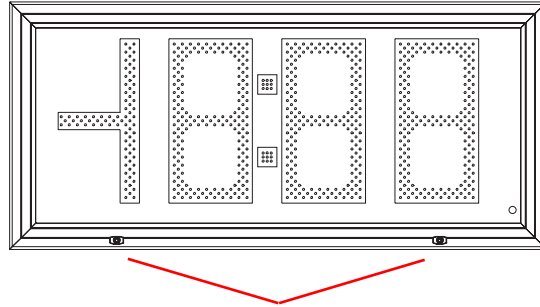

Tamper-resistant latches

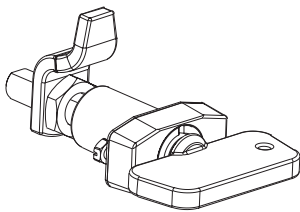

Locking latch, closed, with key inserted

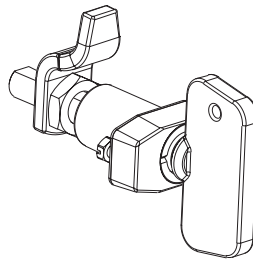

Locking latch, with key turned 90° to the left, to release locking tension

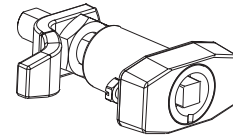

Locking latch, with key turned 180° to the left, to fully unlock the case and with key removed

3. Lift the door and hold the sign open.



4. Unscrew and remove the wing nut on the safety bar against one side of the door.

*Inside view of the case, showing safety bar in stored position inside the door*

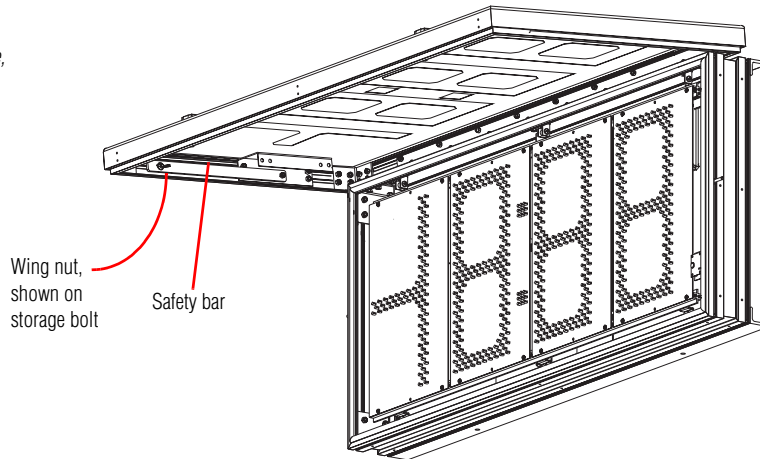

5. Pull the end of the safety bar off the bolt and swing the safety bar downward.

*Inside view of the case, showing safety bar swung down*

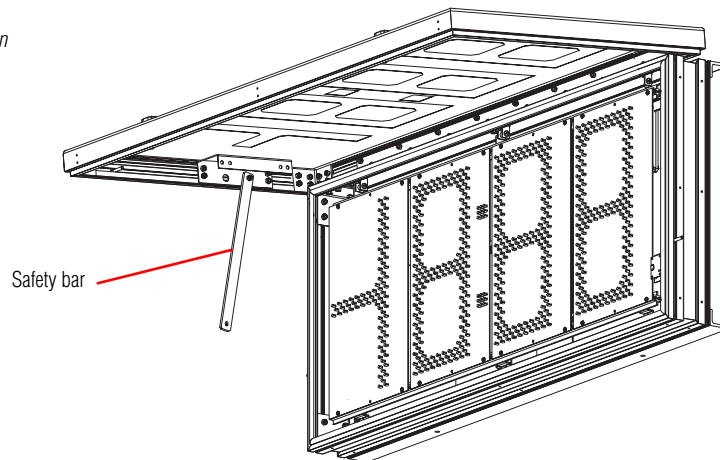

6. Fit the safety bar onto the support bolt on the side of the sign.  
**NOTE:** Remove the protective plastic sleeve from the support bolt. You may choose to store the sleeve by temporarily sliding it onto the bolt where the safety bar was attached.
7. Thread the wing nut onto the support bolt and tighten the nut.

*Outside view of the case, showing safety bar locked down*

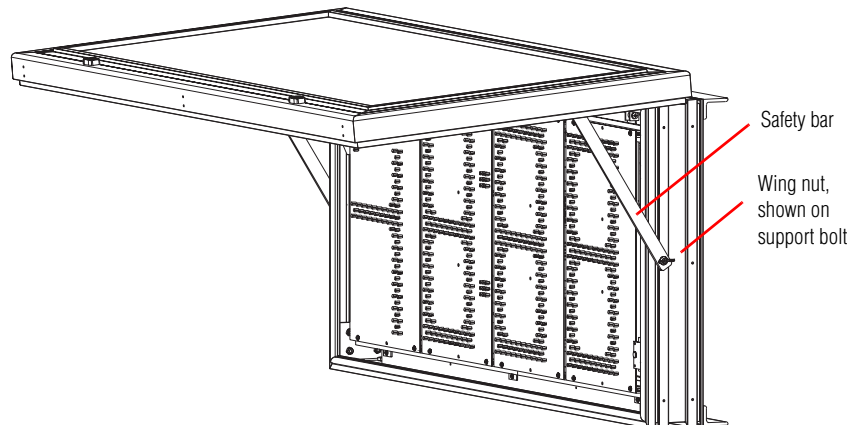

8. Repeat the steps for the second safety bar on the other side of the sign.

## Raising the LED boards

1. Unscrew and remove the screws at the bottom of each internal vertical rail. Retain the screws for use when closing the sign.

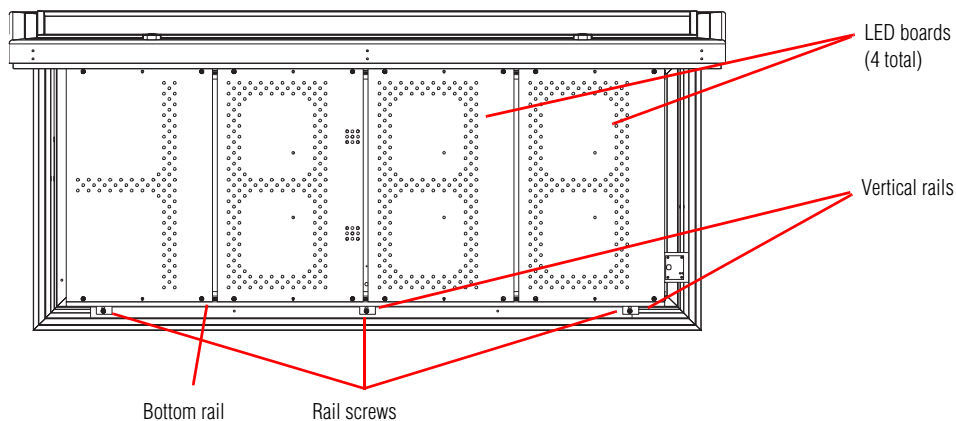

2. Carefully lift the LED boards by placing your fingers in the mounting rail holes — not underneath an LED board. A cable stop prevents the sign from opening too far.
3. Unfasten the prop bar from underneath the LED boards and insert the end into the hole in the bottom bracket.

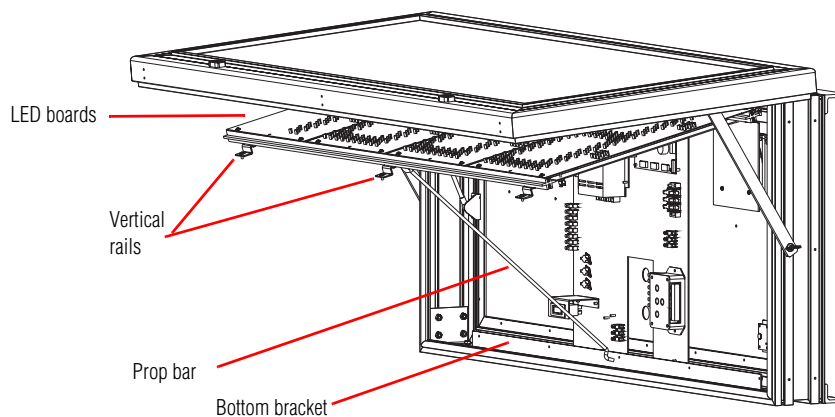

Note: The heater strip and the top and bottom thermostat are not installed in newer signs.

4. Turn the ON/OFF switch OFF.

## Closing and locking the door

1. Turn the ON/OFF switch ON.
2. Holding the LED board rails, fold the prop rod back into the sign and refasten it.
3. Lower the LED boards.
4. Refasten the rail screws to the internal vertical rail.
5. Unfasten each safety bar and replace each one to its storage position inside the sign.  
**NOTE:** Replace the protective plastic sleeve on the support bolts on the side of the sign.
6. Thread the wing nuts onto the safety bar bolts and tighten the wing nuts.
7. Lower the sign's door.
8. Use the latch key to lock the latches that are located along the lower edge of the sign's front.
9. Apply power to the sign.

## Removing the control box from the sign enclosure

The control box is installed inside of the sign. It may be removed and stored outside of the sign.

1. Open the sign according to “Unlocking and opening the door” on page 19.
2. Turn the ON/OFF switch OFF.
3. Unscrew and remove the cover of the control box.

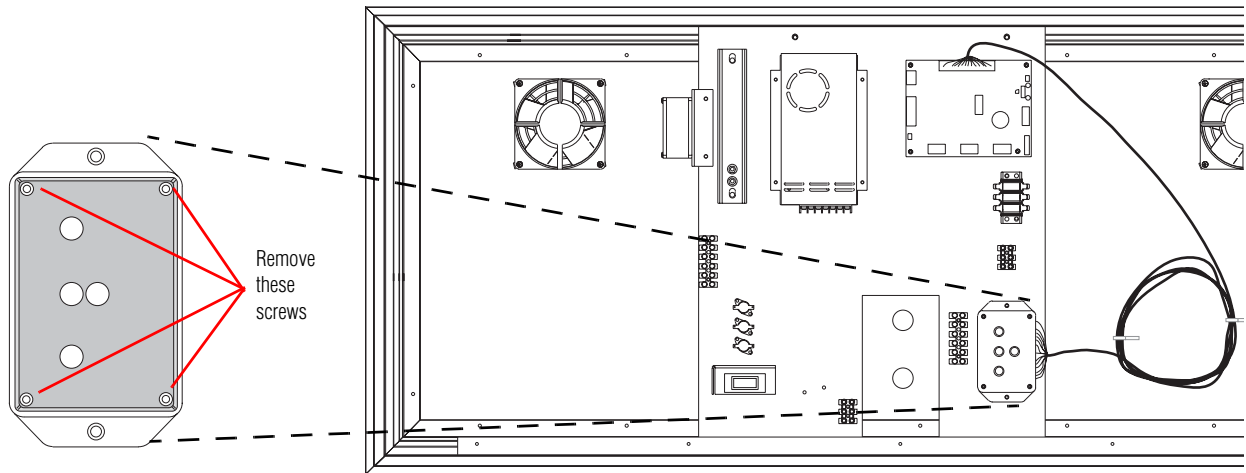

Note: The heater strip and the top and bottom thermostat are not installed in newer signs.

4. (Optional) Unplug the control box connector by pulling it to the right. Do not pull by the wires.

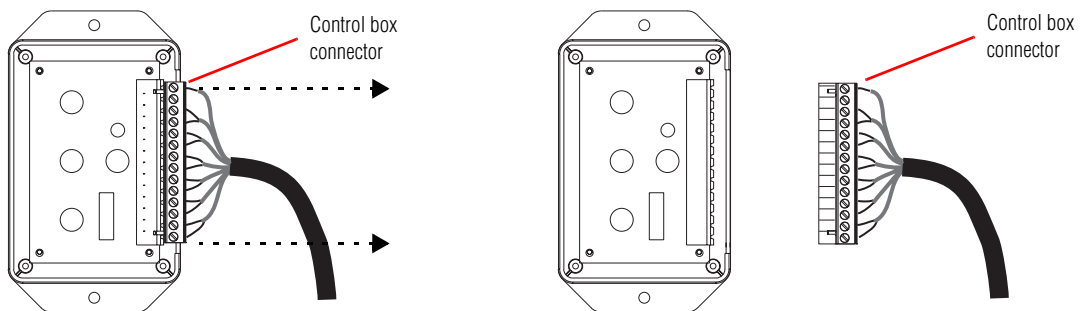

5. Disconnect the wires from the connector by unscrewing the screws and gently pulling out the wires. Each pair of wires is heat-shrunk together so that the wires can be easily reconnected.

6. Carefully wind the ends of the wires together and slide the cable through the conduit opening.

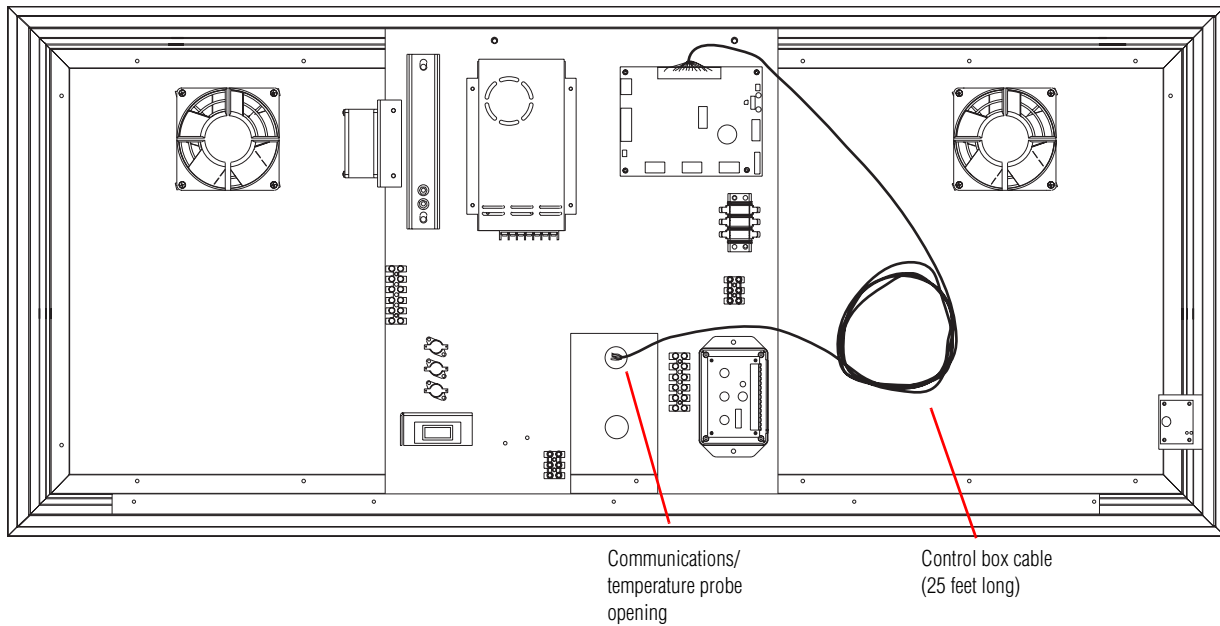

Note: The heater strip and the top and bottom thermostat are not installed in newer signs.

7. Remove the screws holding the control box in the sign enclosure.

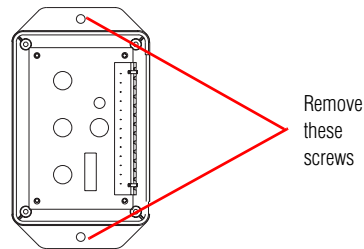

8. Mount the control box outside the sign enclosure.
  - Mount the control box inside a weather-proof container.
  - The control box cable is 25 feet long.
  - Do not allow strain on the cable or connections at either end of the cable.
  - Keep the cable away from the Fans and the heater strip.
  - Be sure to follow all local codes and regulations.

9. Reconnect the wires to the control box connector following the chart below. Each pair of wires includes a black wire coupled with another color.

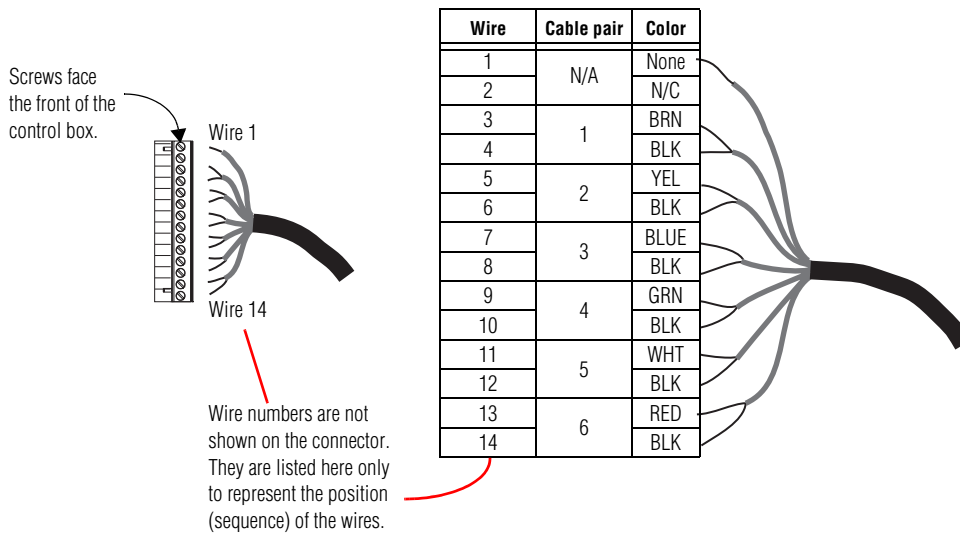

**NOTE:** To see the control box wiring connections *at the controller board*, see “Control box wiring diagram” on page 18.

10. If you unplugged the connector, plug it in to the control box.
11. Replace the cover of the control box and refasten the screws.
12. Close the sign according to “Closing and locking the door” on page 21.
13. Reapply power to the sign.



## Sign Settings

---

### Setting the time

You must use the control box to set the time. See “Using the control box to change sign settings” on page 36.

You can set the hours or the minutes separately. To set them at the same time, press Enter only after completing all of the steps.

#### Setting the hour

1. Press Select on the control box. A blinking line will appear under Character 2 indicating that hours is the function to be set.
2. Press Up or Down on the control box as appropriate to set the hour.  
**NOTE:** The colon is only displayed during PM time.
3. If you are only setting the hour, press Enter on the control box. The time will be displayed on your sign showing the new hour.

If you also intend to set the minutes, do not press Enter yet.

#### Setting the minutes

1. Press Select on the control box twice (once if you are setting hours and minutes at the same time). A blinking line will appear under Characters 3 and 4 indicating that minutes is the function to be set.
2. Press Up or Down as appropriate to set the minutes.
3. Press Enter. The time will be displayed on your sign showing the new minutes.

Seconds are set to zero whenever hours or minutes are set. Specifically, the seconds are set to zero the instant that the Enter button is released.

## Setting the hold time

Hold time indicates how long the time or temperature is to be displayed on the sign. You may set the hold time using either the DIP switches or the control box. See “Using the DIP switches to change sign settings” on page 33. The hold time can be as short as one second or as long as eight.

**NOTE:** Settings changed using the control box override the corresponding DIP switch settings.

**NOTE:** Changes to DIP switch settings take effect only after removing and reapplying power.

### Setting the hold time with DIP switches

If you use the DIP switches to set the hold time, you can select a hold time of 2, 4, 6, or 8 seconds.

1. Remove power from the sign at the external circuit breaker.
2. Open the sign according to “Unlocking and opening the door” on page 19.
3. Remove power from the sign internally by turning the ON/OFF switch OFF.
4. Use switches 7 and 8 on DIP switch 1 to set the hold time. See the table for the available settings.

Hold time	Switch 7	Switch 8
2 seconds (Factory setting)	Off	Off
4 seconds	On	Off
6 seconds	Off	On
8 seconds	On	On

5. Apply power to the sign internally by turning the ON/OFF switch ON.
6. Close the sign according to “Unlocking and opening the door” on page 19.
7. Apply power to the sign at the external circuit breaker.

### Setting the hold time with the control box

If you use the control box to set the hold time, you can select one of 15 different half-second settings, ranging from 1 second to 8 seconds.

1. Press Select on the control box three times. An H in the Character 2 position, and a blinking line under Characters 3 and 4 indicate that hold time is the function to be set.
2. Press Up or Down on the control box as appropriate to set the hold time. See the table for the available hold time settings.

Select this setting	2	3	4	5	6	7	8	9	10	11	12	13	14	15	16
for a hold time of (in seconds)	1	1.5	2	2.5	3	3.5	4	4.5	5	5.5	6	6.5	7	7.5	8

3. Press Enter. The new hold time will be applied.

## Setting the dimming percentage

Each sign is equipped with a Sensor that detects the level of light in the sign's location and causes the LEDs to either dim or brighten for maximum visibility. At dusk, or when less light is detected, the sign will be dimmed. At dawn, or when more light is present, the sign will resume full brightness to ensure the best visibility.

A sign's dimming percentage can be set independently or slave signs can be configured to use the master sign's settings. See "Setting the dimming percentage on a slave sign with DIP switches" on page 29.

**NOTE:** Settings changed using the control box override the corresponding DIP switch settings.

**NOTE:** Changes to DIP switch settings take effect only after removing and reapplying power.

### Setting the dimming percentage on a master or single sign with DIP switches

If you use the DIP switches on a master sign to set the dimming percentage, you can select 4 dimming levels.

1. Remove power from the sign at the external circuit breaker.
2. Open the sign according to "Unlocking and opening the door" on page 19.
3. Remove power from the sign internally by turning the ON/OFF switch OFF.
4. Use switches 5 and 6 on DIP switch 1 to set the dimming percentage. See the table for the available settings.

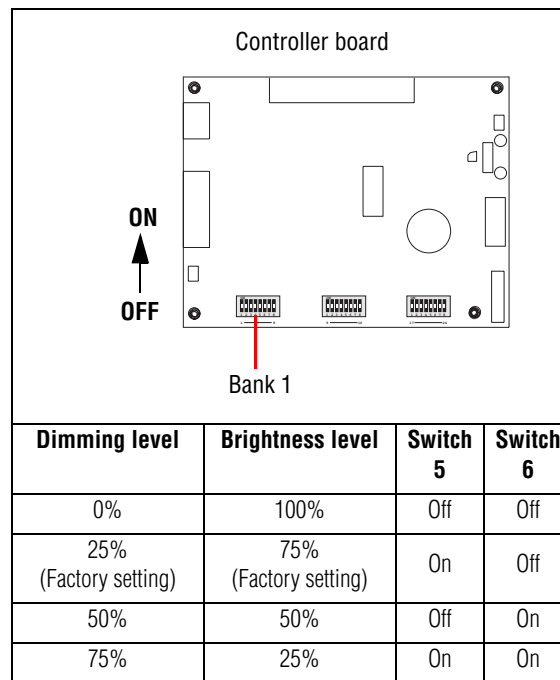

5. Apply power to the sign internally by turning the ON/OFF switch ON.
6. Close the sign according to "Closing and locking the door" on page 21.
7. Apply power to the sign at the external circuit breaker.

### Setting the dimming percentage with the control box

If you use the control box to set the dimming percentage, you can select 8 dimming levels.

1. Press Select on the control box four times. A *d* in the Character 2 position, and a blinking line under Character 4 indicate that dimming percentage is the function to be set.
2. Press Up or Down on the control box as appropriate to set the dimming percentage. See the table for the available dimming percentage settings.

<b>Setting</b>	0	1	2	3	4	5	6	7
<b>Dimming</b>	0%	13%	25%	37%	50%	62%	75%	87%
<b>Brightness*</b>	100%	87%	75%	63%	50%	38%	25%	13%

\* Brightness is the inverse of dimming. Therefore, a dimming percentage of 0% is the same as a brightness percentage of 100%, a dimming percentage of 13% is the same as a brightness percentage of 87%, and so on.

3. Press Enter. The new dimming percentage will be applied.

### Setting the dimming percentage on a slave sign with DIP switches

1. Remove power from the slave sign at the external circuit breaker.
2. Open the slave sign according to “Unlocking and opening the door” on page 19.
3. Remove power from the sign internally by turning the ON/OFF switch OFF.
4. If you want the dimming percentage on the slave sign to match the level set on the master sign, set switch 7 on DIP switch 1 on the controller board in the slave sign to ON.

If you want the dimming percentage on the slave sign to be different from the dimming percentage on the master sign, set switch 7 on DIP switch 1 on the controller board in the slave sign to OFF.

5. Use switches 4, 5, and 6 on DIP switch 1 to set the dimming percentage. See the table for the available settings.

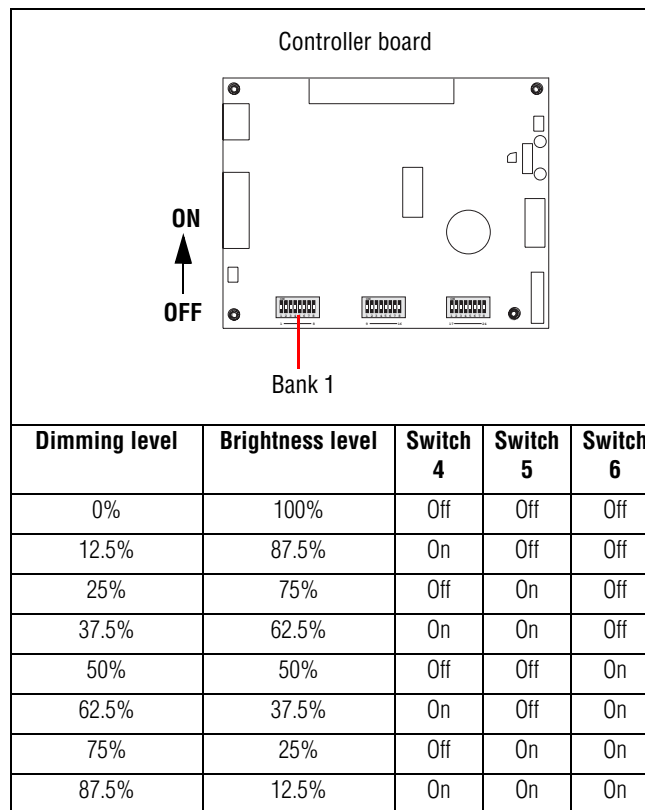

6. Apply power to the sign internally by turning the ON/OFF switch ON.
7. Close the sign according to “Closing and locking the door” on page 21.
8. Apply power to the sign at the external circuit breaker.

## Making display selections

Using the DIP switches, you can select whether or not to display the time, Fahrenheit temperature, and/or Centigrade temperature on your sign. See “Using the DIP switches to change sign settings” on page 33.

**NOTE:** Changes to DIP switch settings take effect only after removing and reapplying power.

### Selecting information to display

1. Remove power from the sign at the external circuit breaker.
2. Open the sign according to “Unlocking and opening the door” on page 19.
3. Remove power from the sign internally by turning the ON/OFF switch OFF.
4. Use switches 1, 2, and 3 on DIP switch 2 to make your display selections. See the table for the available settings.

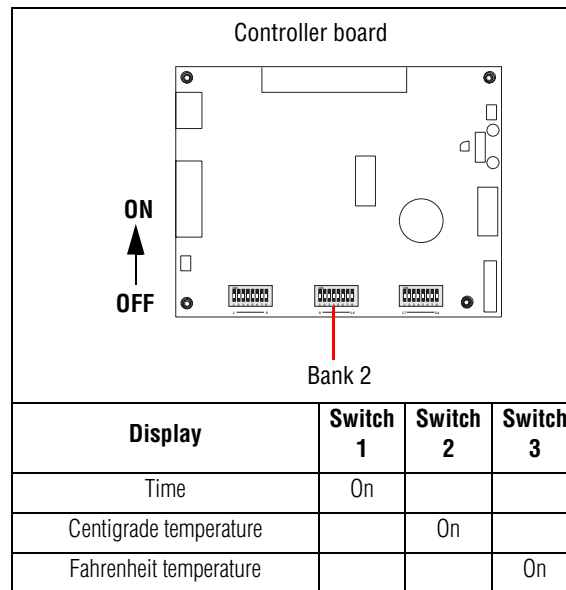

5. Apply power to the sign internally by turning the ON/OFF switch ON.
6. Close the sign according to “Closing and locking the door” on page 21.
7. Apply power to the sign at the external circuit breaker.

## Making symbol selections

Using switch 4 on bank 1, you can select which temperature symbol will be displayed on your sign. See the table for the available settings.

**NOTE:** Changes to DIP switch settings take effect only after removing and reapplying power.

### Selecting the symbol to be displayed

1. Remove power from the sign at the external circuit breaker.
2. Open the sign according to “Unlocking and opening the door” on page 19.
3. Remove power from the sign internally by turning the ON/OFF switch OFF.
4. Use switch 4 on DIP switch 1 to make your symbol selections. See the table for the available settings.

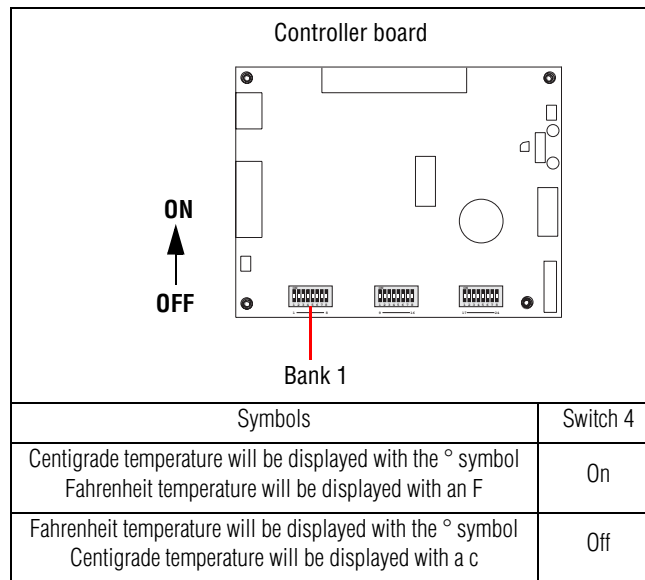

5. Apply power to the sign internally by turning the ON/OFF switch ON.
6. Close the sign according to “Closing and locking the door” on page 21.
7. Apply power to the sign at the external circuit breaker.

### Selecting the font to be displayed

1. Remove power from the sign at the external circuit breaker.
2. Open the sign according to “Unlocking and opening the door” on page 19.
3. Remove power from the sign internally by turning the ON/OFF switch OFF.
4. Use switch 1 on DIP switch 1 to make your font selection. See the table for the available settings.

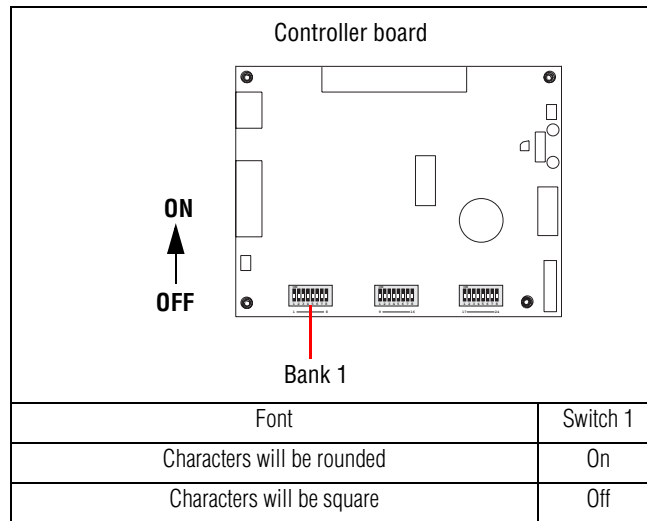

5. Apply power to the sign internally by turning the ON/OFF switch ON.
6. Close the sign according to “Closing and locking the door” on page 21.
7. Apply power to the sign at the external circuit breaker.



You can change the default settings on your sign using the DIP switches inside the sign and/or by using the control box.

If you are installing more than one sign and using a master/slave configuration, most of the settings for the master sign will apply to the slave sign. However, you can set the dimming percentage and diagnostic testing options independently at the slave sign.

**NOTE:** Settings changed using the control box override the corresponding DIP switch settings.

**NOTE:** Time, hold time, and dimming settings made using the control box are saved by a backup battery if power is lost or if the sign is turned off.

Using either DIP switches or the control box, you can configure these settings for the sign:

Setting	Single or master		Slave
	Set using DIP switches	Set using control box	Set using DIP switches
Set clock time (hours and minutes)		X	
Set length of hold time	X	X	
Set dimming percentage	X	X	X
Display any combination of: Time (Yes or No) Temperature in Fahrenheit (Yes or No) Temperature in Centigrade (Yes or No)	X X X		
Representation of temperature: Centigrade displayed as: ° and Fahrenheit displayed as: "F" or Fahrenheit displayed as: ° and Centigrade displayed as: "c"	X		
Set font to use (square or rounded)	X		
Set diagnostic tests to run	X		X

## Using the DIP switches to change sign settings

**NOTE:** Changes to DIP switch settings take effect only after removing and reapplying power.

1. Remove power from the sign at the external circuit breaker.
2. Open the sign according to "Unlocking and opening the door" on page 19.
3. Remove power from the sign internally by turning the ON/OFF switch OFF.
4. See the applicable section to change the following settings:
  - "Setting the hold time" on page 26
  - "Setting the hold time" on page 26
  - "Setting the dimming percentage" on page 27
  - "Making display selections" on page 30
  - "Making symbol selections" on page 31
  - "Selecting the font to be displayed" on page 32
5. Apply power to the sign internally by turning the ON/OFF switch ON.
6. Close the sign according to "Closing and locking the door" on page 21.
7. Apply power to the sign at the external circuit breaker.

### DIP switch settings

The table below lists all the settings available for a single sign installation, or for a master sign in a master/slave configuration.

Controller board			
Option	DIP switch	On	Off
<b>Font</b>	Bank 1, switch 1	Rounded (Factory setting)	Square
<b>Time mode</b>	Bank 1, switch 2	24-hour time is an option. It must be installed at the factory.	12-hour (Factory setting)
<b>Reserved</b>	Bank 1, switch 3	Do not use	N/A (Factory setting)
<b>Temperature symbol</b>	Bank 1, switch 4	Centigrade: ° Fahrenheit: <b>F</b>	Fahrenheit: ° Centigrade: <b>c</b> (Factory setting)
<b>Dimming percentage</b>	Bank 1, switch 5	See "Setting the dimming percentage on a master or single sign with DIP switches" on page 27.	
	Bank 1, switch 6		
<b>Hold time</b>	Bank 1, switch 7	See "Setting the hold time with DIP switches" on page 26.	
	Bank 1, switch 8		
<b>Display time</b>	Bank 2, switch 1	Time is displayed (Factory setting)	Time is not displayed
<b>Display Centigrade</b>	Bank 2, switch 2	Centigrade temperature is displayed	Centigrade temperature is not displayed (Factory setting)
<b>Display Fahrenheit</b>	Bank 2, switch 3	Fahrenheit temperature is displayed (Factory setting)	Fahrenheit temperature is not displayed
<b>Reserved</b>	Bank 2, switch 4	<b>Off</b>	
	Bank 2, switch 5		
	Bank 2, switch 6		
	Bank 2, switch 7		
	Bank 2, switch 8		
	Bank 3, switch 1		
	Bank 3, switch 2		
	Bank 3, switch 3		
	Bank 3, switch 4		
	Bank 3, switch 5		
	Bank 3, switch 6		
	Bank 3, switch 7		
Bank 3, switch 8			

The table below lists all the settings available for a slave sign in a master/slave configuration.

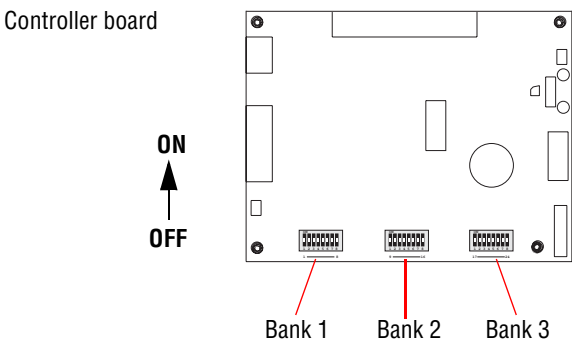
Controller board			
Option	DIP switch	On	Off
<b>Reserved</b>	Bank 1, switch 1	Off	
	Bank 1, switch 2		
	Bank 1, switch 3		
<b>Dimming percentage</b>	Bank 1, switch 4	See "Setting the dimming percentage on a slave sign with DIP switches" on page 29.	
	Bank 1, switch 5		
	Bank 1, switch 6		
<b>Enable/disable independent dimming</b>	Bank 1, switch 7		
<b>Reserved</b>	Bank 1, switch 8	Off	
	Bank 2, switch 1		
	Bank 2, switch 2		
	Bank 2, switch 3		
	Bank 2, switch 4		
	Bank 2, switch 5		
	Bank 2, switch 6		
	Bank 2, switch 7		
	Bank 2, switch 8		
	Bank 3, switch 1		
	Bank 3, switch 2		
	Bank 3, switch 3		
	Bank 3, switch 4		
	Bank 3, switch 5		
	Bank 3, switch 6		
	Bank 3, switch 7		
Bank 3, switch 8			

## Using the control box to change sign settings

### Control box features

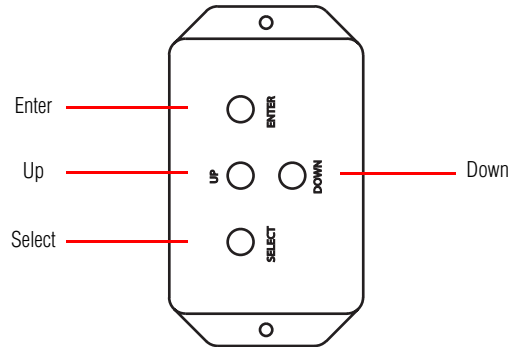

Button	Description
Select	Determines the function to set: <ul style="list-style-type: none"> <li>• Hours</li> <li>• Minutes</li> <li>• Hold time</li> <li>• Dimming percentage</li> </ul>
Up	Scrolls up through the next options for the chosen function.
Down	Scrolls down through the prior options for the chosen function.
Enter	Sets the function to the option chosen. If Enter is not pressed, the sign reverts to the prior setting.

Press and hold the buttons on the control box for at least one second. Pressing a button for less than one second will not activate any change.

The Select button cycles one time through all the functions: hours, minutes, hold time, and dimming percentage. However, if the display time DIP switch (switch 1 on DIP switch 2) is set to OFF, indicating that time is not displayed on the sign, then the Select button only cycles through hold time and dimming percentage.

Use this diagram as a reference for character position on the sign.

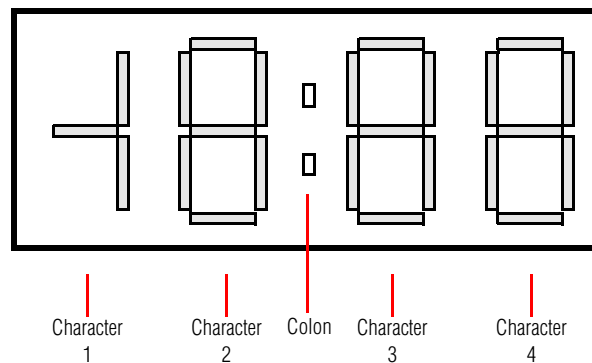

## Diagnostic tests

Several diagnostic tests may be conducted to assess the operation of the sign. DIP switches are used set the sign in diagnostics mode and select the test to be conducted. For all of the diagnostic tests, the brightness of the LEDs is the same as the dimming percentage defined and recorded when power is applied to the sign. Running diagnostic tests resets the sign to settings made using the DIP switches rather than the control box.

### To run diagnostic tests on a master sign

1. Remove power from the master sign at the external circuit breaker.
2. Open the master sign according to “Unlocking and opening the door” on page 19.
3. Remove power from the sign internally by turning the ON/OFF switch OFF.
4. Turn switches 1, 2, and 3 on DIP switch 2 OFF.
5. Use switches 3 and 4 on DIP switch 1 to select the test to be conducted. See the table for the available diagnostic tests.

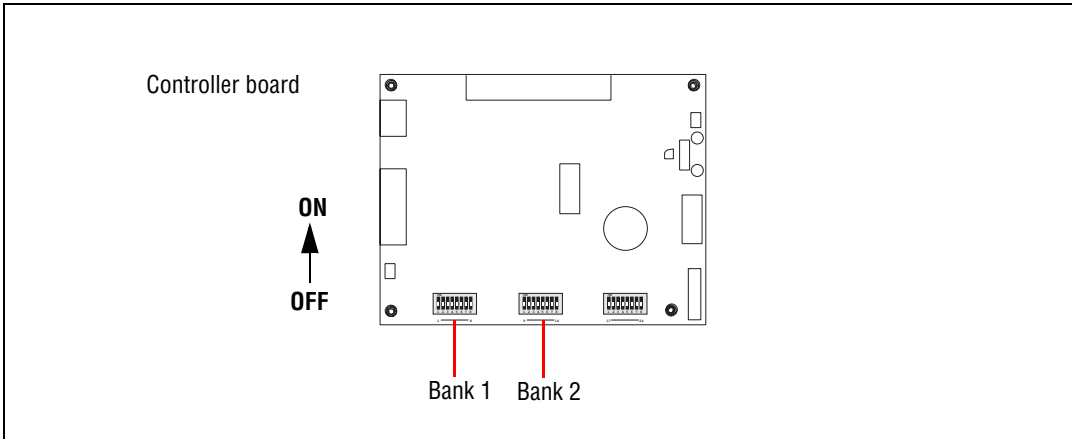

The diagram shows a rectangular controller board with various components. On the left side, there is a vertical switch labeled 'ON' with an upward-pointing arrow and 'OFF' with a downward-pointing arrow. At the bottom of the board, there are two DIP switch banks labeled 'Bank 1' and 'Bank 2'. Bank 1 has three switches, and Bank 2 has three switches. The board also features several other components like resistors, capacitors, and a circular component.

Diagnostic	Description	Bank 1 Switch 3	Bank 1 Switch 4	Bank 2 Switch 1, 2, 3
Segment scan	Displays each segment on all characters in sequence.	Off	Off	Off
Lamp test	Lights all the LEDs of all characters, alternating between square and round corners, using the dimming percentage currently set.	On	Off	Off
Temperature test	Displays the internal temperature of the sign in Centigrade, using the dimming percentage currently set.	Off	On	Off
Internal component test	To be used only by qualified Adaptive technicians.	On	On	Off

6. Apply power to the master sign internally by turning the ON/OFF switch ON.
7. Close the sign according to “Closing and locking the door” on page 21.
8. Apply power to the master sign at the external circuit breaker.

### To run diagnostic tests on a slave sign

1. Remove power from the slave sign at the external circuit breaker.
2. Open the slave sign according to “Unlocking and opening the door” on page 19.
3. Remove power from the sign internally by turning the ON/OFF switch OFF.
4. Turn switch 3 on DIP switch 1 ON.

- Use switches 1 and 2 on DIP switch 1 to select the test to be conducted. See the table for the available diagnostic tests.

Controller board

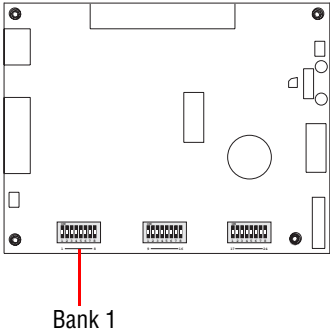

Bank 1

Diagnostic	Description	Switch 1	Switch 2	Switch 3
Segment scan	Displays each segment on all characters in sequence. (Factory setting)	Off	Off	On
Lamp test	Lights all the LEDs of all characters, alternating between square and round corners, using the dimming percentage currently set.	On	Off	On
Temperature test	Displays the internal temperature of the sign in Centigrade, using the dimming percentage currently set.	Off	On	On
Internal component test	To be used only by qualified Adaptive technicians.	On	On	On

- Apply power to the slave sign internally by turning the ON/OFF switch ON.
- Close the sign according to "Closing and locking the door" on page 21.
- Apply power to the slave sign at the external circuit breaker.

## Sign specifications

---

### EMI compliance

This equipment has been tested and found to comply with the limits for a Class A digital device, pursuant to Part 15 of the FCC Rules. These limits are designed to provide reasonable protection against harmful interference when the equipment is operated in a commercial environment.

This equipment generates, uses, and can radiate radio frequency energy and, if not installed and used in accordance with installation guidelines, may cause harmful interference to radio communications. Operation of this equipment in a residential area is likely to cause harmful interference, in which case the user will be required to correct the interference at his own expense.

### To view sign identification information

---

When power is applied to the sign, the following information will be displayed:

- The Adaptive Micro Systems product number for the sign. 1165 is the number assigned to the AlphaEclipse Time and Temperature sign.
- The number assigned to the micro controller chip. A single sign or a master in a master/slave configuration will be identified as "002" while the micro controller chip installed in a slave sign in a master/slave configuration will be identified as "003."
- The version of the firmware contained in the micro controller chip, for example, "100" or "101."
- The time and temperature as they are currently set. To change these settings, see "Checking the time" on page 13.

### Temperature protection

---

The sign is protected from extreme temperatures by heaters and cooling fans. These are activated based on the internal temperature of the sign, not the external temperature and are not regulated by any DIP switch settings.

#### Cold protection

- At or below 4° C (40° F), an internal heater strip will automatically turn on. Air warmed by the heater strip will be blown by a fan throughout the enclosure. If the temperature rises to or above 16° C (60° F), then the internal heaters will turn off.

#### Heat protection

- At or above 29° C (85° F), a cooling fan will automatically turn on. If the temperature drops to 19° C (67° F), then the cooling fans will turn off.
- At or above 70° C (158° F), over-temperature dimming will occur. The LED output of the sign will automatically be reduced to 50% of its maximum output. If the temperature falls to 68° C (154° F), then over-temperature dimming will stop.
- At or above 80° C (176° F), the sign will automatically shut down to protect against damage. If the temperature falls to 78° C (172° F) or less, the sign will resume operation in over-temperature dimming mode, or 50% brightness.

## Technical specifications

Model Number	LED Color	Input Current (amperes)		Dimensions		Approx. Weight
		120 V @ 60 Hz	240 V @ 60 Hz	L x H x D	Mounting Dimensions	
				<p>The drawing shows a perspective view of the sign with dimension lines. 'L' is the length, 'H' is the height, and 'D' is the depth.</p>	<p>The drawing shows a perspective view of the sign with dimension lines. 'MH' is the mounting height and 'MD' is the mounting depth.</p>	
AE-1181-A	Amber	1.0	0.5	60 x 27.7 x 5.3 (in) 152.4 x 70.4 x 13.5 (cm)	MH = 24.3 in (61.7 cm) MD = 7.2 in (18.3 cm)	120 (lbs) 54.4 (kg)
AE-1181-R	Red	1.0	0.5	60 x 27.7 x 5.3 (in) 152.4 x 70.4 x 13.5 (cm)	MH = 24.3 in (61.7 cm) MD = 7.2 in (18.3 cm)	120 (lbs) 54.4 (kg)